

Serie W09 inclinata 15°

Supporti inclinati di 15° ad innesto in fresata laterale. Per piani a partire da 19 fino a 40 mm di spessore.

W09 Series 15° inclined

15° inclined supports to be inserted into milled side. For shelves from 19 up to 40 mm thick.



In abbinamento a CAV.CLIP.GRE per bloccaggio dei piani.

To be used with CAV.CLIP.GRE to block the shelf.

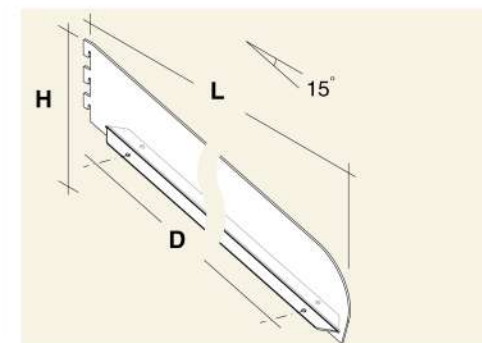

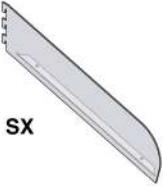
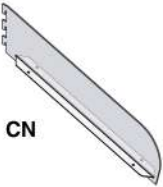
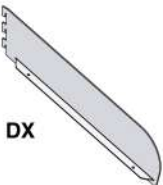
	Codici Codes	Al	P _s	L	H	D	kg
 SX sinistro left	W09.I15.SX40.____		415	413,5	212	301	80
 CN centrale central	W09.I15.CN40.____		415	413,5	212	301	80
 DX destro right	W09.I15.DX40.____		415	413,5	212	301	80

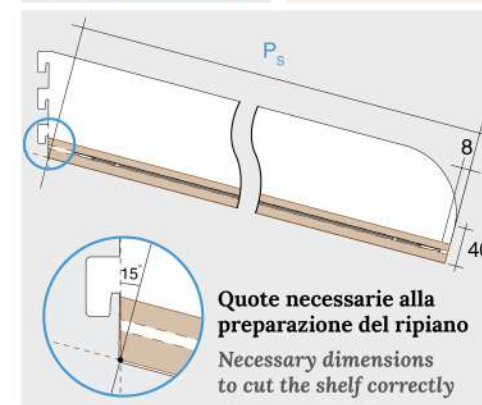
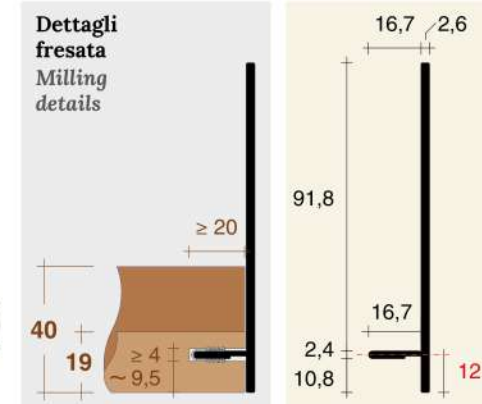
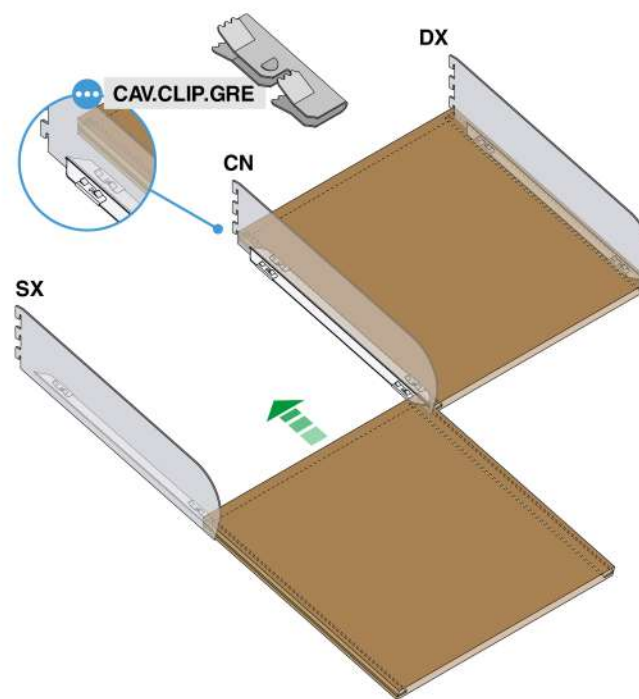

Finiture Finishings	Alluminio Aluminium	Al
Argento satinato Satinized Silver		NAT
Nero Black		ANE*
Superficie simil-acciaio inox Stainless steel optical		SSO*

codice code
XXX.XXXX.XXX* Asterisco = la finitura potrebbe non essere in pronta consegna.
Asterisk = finishing not always ready in stock.

kg Capacità di carico per coppia di supporti su campata 60 cm.
Loading capacity of 2 supports at 60 cm distance.

Quote espresse in millimetri.
Dimensions are in millimeters.

Accessori correlati
Related accessories

FIT
ART

Serie W09

Supporti ad innesto in fresata laterale. Per piani a partire da 19 fino a 40 mm di spessore.

W09 Series

Supports to be inserted into milled side. For shelves from 19 up to 40 mm thick.



In abbinamento a CAV.CLIP.GRE per bloccaggio dei piani o VEN.GLA5.TRA per lastre in vetro.

To be used with CAV.CLIP.GRE to block the shelf or with VEN.GLA5.TRA for glass slabs.

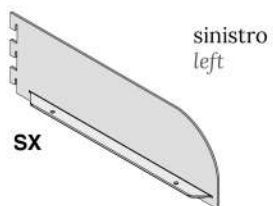

SX

sinistro
left

Codici Codes	Al	P _s	H	D	kg
W09.SX30.____		314	105	193,5	100
W09.SX35.____		365	105	244,5	100
W09.SX40.____		416	105	295,5	100
W09.SX45.____		467	105	346,5	85/99
W09.SX50.____		518	105	397,5	80/99
W09.SX55.____		569	105	448,5	-

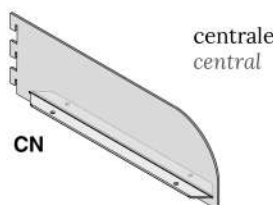

CN

centrale
central

W09.CN30.____		314	105	193,5	100
W09.CN35.____		365	105	244,5	100
W09.CN40.____		416	105	295,5	100
W09.CN45.____		467	105	346,5	85/99
W09.CN50.____		518	105	397,5	80/99
W09.CN55.____		569	105	448,5	-

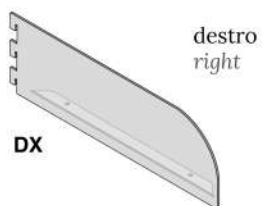

DX

destro
right

W09.DX30.____		314	105	193,5	100
W09.DX35.____		365	105	244,5	100
W09.DX40.____		416	105	295,5	100
W09.DX45.____		467	105	346,5	85/99
W09.DX50.____		518	105	397,5	80/99
W09.DX55.____		569	105	448,5	-

Finiture Finishings	Alluminio Aluminium	Al
Argento satinato Satinized Silver		NAT
Nero Black		ANE*
Superficie simil-acciaio inox Stainless steel optical		SSO*

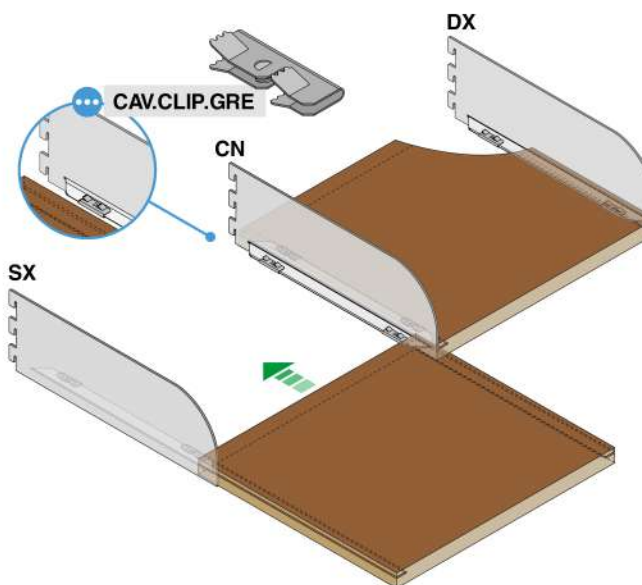

Ventose, per applicazioni con lastre in vetro, a filo con spessori di 8 mm
Suction cups, for glass slabs, 8 mm thickness to fit flush

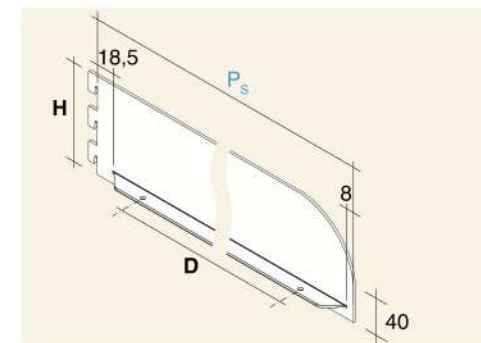

Dettagli
fresata
Milling
details

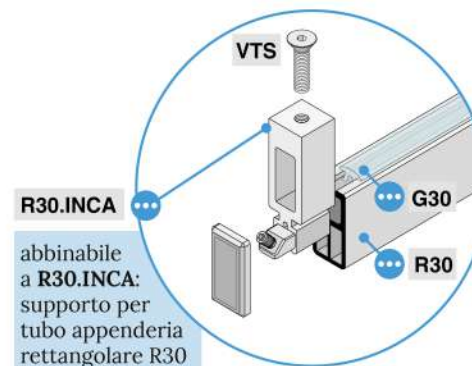
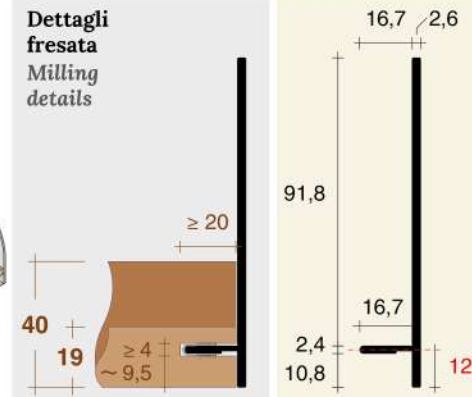

R30.INCA

abbinabile a R30.INCA: supporto per tubo appendieria rettangolare R30
to be matched with R30.INCA: support for rectangular hangrail R30

Note per il montaggio

Notes for assembly

SUPPORTI AD INNESTO IN FRESATA LATERALE:
Serie T19, T25, T30, T35, W09, W25 ed F19

SUPPORTS TO BE INSERTED INTO MILLED SIDE:
T19, T25, T30, T35, W09, W25 and F19 Series

Montaggio con clips per piani in legno
o con ventose per lastre in vetro da 8 mm

Assembly with clips for wooden shelves
or with suction cups for 8 mm glass slabs

Calcolo della PROFONDITÀ e LARGHEZZA del RIPIANO in base al modello di cremagliera scelto
SHELF DEPTH and WIDTH calculation according to the choice of the profile's model

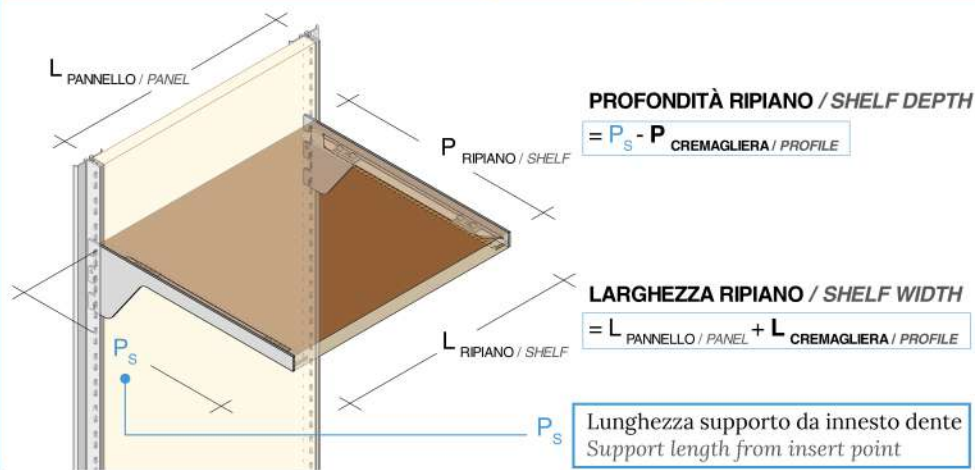

					
P CREMAGLIERA / PROFILE	9,5	9,5	6	6	1
L CREMAGLIERA / PROFILE	5	4,5	4,5	4,5	4,5

Considerare tolleranze di lavorazione $\pm 0,5$ mm sui valori indicati in tabella. Si raccomandano prove preventive.
Consider $\pm 0,5$ mm tooling tolerance on the values indicated in the table. Preparatory tests are highly recommended.

Modalità di smontaggio del piano in legno
How to disassemble the wooden shelf

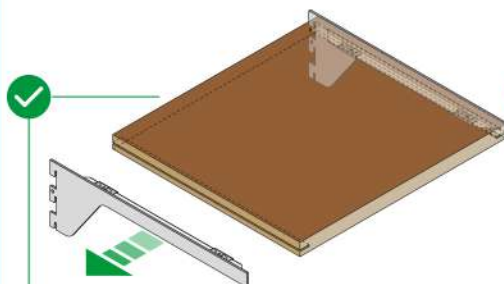

Per smontare il piano, tirare lateralmente
To remove the shelf, pull laterally.

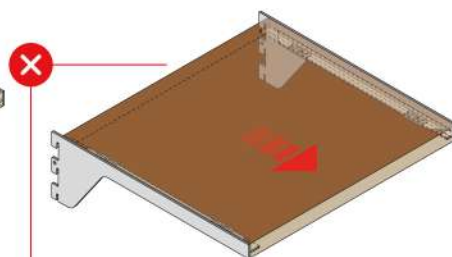

Il piano NON è smontabile frontalmente:
le alette delle clip, alzandosi, oppongono resistenza.

The shelf IS NOT frontally removable:
the clip flaps, once up, fix the shelf.

Applicazione con lastre in vetro sp. 8 mm a filo
Application with 8 mm thick glass slabs to fit flush

